

SPEC # _____

QUANTITY _____

APPLICATION

ICE

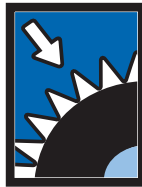

AT A GLANCE

Aqua-Pure[®] Models ICE160-S and ICE165-S single-cartridge water filtration systems help provide consistent high-quality water for commercial cubers and flakers by reducing the harmful effects of sediment, chlorine, and scale at flow rates to 3.34 gpm (12.6 lpm). Built-in scale inhibition reduces the ability of calcium and magnesium to precipitate on the evaporator plates as hard scale.

- **ICE160-S** combines chlorine taste and odor reduction with cyst, bacteria and sediment reduction, and helps provide protection from the potentially harmful effects of chlorine corrosion and scale for up to 35,000 gallons (132,489 liters).
- **ICE165-S** combines chlorine taste and odor reduction with sediment reduction for higher turbidity water and helps provide protection from the potentially harmful effects of chlorine corrosion and scale for up to 35,000 gallons (132,489 liters).

PRODUCT BENEFITS

- Effectively reduces sediment and chlorine for better equipment protection and clearer, great tasting ice.
- Revolutionary **Integrated Membrane Pre-Activated Carbon Technology ("IMPACT")** dual-zone media cartridge construction combines a membrane in series with premium activated carbon to help provide superior throughput and cartridge life.
- Cartridge Life Warranted*.
- Certified by NSF to Standard 53 for cyst reduction (ICE160-S system).
- NSF Standard 42 and/or FDA CFR-21 compliant.
- Reduces up to 99.99% of common water-borne heterotrophic bacteria by membrane filtration as tested by CUNO (ICE160-S system).
- Built-in scale inhibitor reduces lime scale build-up on evaporator plates as tested by CUNO.
- SQC – Sanitary Quick Change – encapsulated cartridge design allows for fast and easy change-outs with a 1/4 turn while minimizing the possibility of leakage and contamination.
- 1/2" FNPT horizontal inlet and outlet ports allow direct or easily adaptable connections to existing plumbing lines.
- Exhausted cartridges may be incinerated for environmentally conscious disposal.

PRODUCT SPECIFICATIONS

Model Number	Part Number	Reduction Claims	Micron Rating	Capacity	Service Flow Rate	Application	Replacement Cartridge	Sizing
ICE160-S	56163-03	Cyst, Bacteria, Sediment, Chlorine Taste and Odor, Scale	0.2'	35,000 gallons (132,489 liters)	3.34 gpm (12.6 lpm)	Most Normal Water	HF60-S: 56134-05	Low Flow Cubers to 1,450 lbs (659 kg) High Flow Cubers to 1,000 lbs (454 kg) Flakers to 2,400 lbs (1,089 kg)
ICE165-S	56163-04	Sediment, Chlorine Taste and Odor, Scale	3.0	35,000 gallons (132,489 liters)	3.34 gpm (12.6 lpm)	Higher Turbidity Water	HF65-S: 56134-09	Low Flow Cubers to 1,450 lbs (659 kg) High Flow Cubers to 1,000 lbs (454 kg) Flakers to 2,400 lbs (1,089 kg)

* See Aqua-Pure Commercial Products Price Book for Terms and Conditions
 † NSF Certified for Particulate, Class I

Aqua-Pure® Commercial Products

SPEC # _____
QUANTITY _____
MODEL NUMBER _____
PART NUMBER _____

Aqua-Pure®
COMMERCIAL PRODUCTS
ICE160-S/ICE165-S

PHYSICAL SPECIFICATIONS

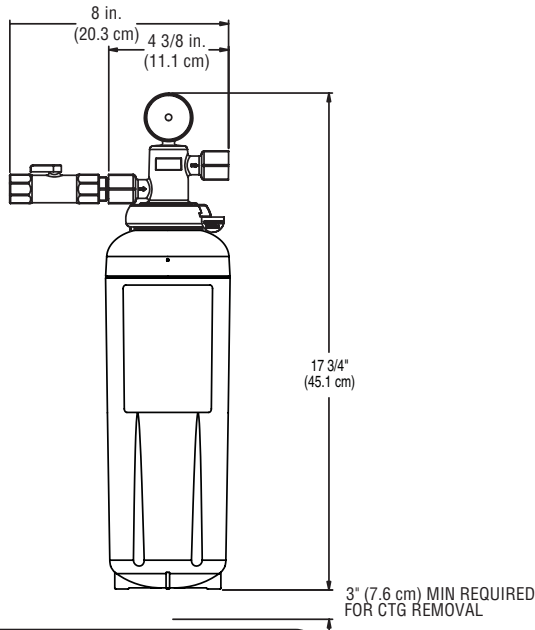

- System includes a head assembly with pressure gauge, inlet-water shutoff valve assembly (comes with 1/2" NPT nipple), mounting bracket, and single cartridge filter.
- Inlet and outlet plumbing connections are 1/2" FNPT.
- Filter cartridges are double o-ring seal type.
- System maximum operating pressure of 125 psi (862 kPa) and operating temperature of 100°F (38°C).
- Recommended service flow rate is up to 3.34 gpm (12.6 lpm).
- Filter cartridges incorporate carbon block media protected by a pleated pre-filter membrane and a scale inhibitor.
- System is NSF Standard 42 and/or CFR-21 compliant.
- Cartridge body is constructed from high-impact glass-filled polypropylene.
- Cartridges are sanitary in design, requiring no contact with the filter media during cartridge change-out.
- Filter cartridges require no pre-activation.
- A NSF Performance Data Sheet (PDS) is included.
- Shipping weight: 4.1 lbs (1.9 kg) per case

IMPORTANT INSTALLATION TIPS

These installation tips are for informational purposes only and are not intended to be used as actual installation instructions. CAUTION: To reduce the risk of property damage due to water leakage, read, follow, and understand the Installation and Use instruction guide BEFORE installation and use of this system.

- Shut off downstream equipment prior to installation of the system.
- Choose mounting location to support full system weight when operating.
- Do not exceed operating parameters for temperature or pressure. System maximum operating pressure of 125 psi (862 kPa) and operating temperature of 100°F (38°C). If pressure exceeds 125 psi, a pressure limiting valve must be installed.
- Do not install outdoors.
- For commercial use only.
- Use on Cold Water Line Only
- Change cartridge at least every six months.

LIMITED 5 YEAR WARRANTY

CUNO Incorporated makes no guarantees or warranties, expressed or implied, including, but not limited to, any implied warranty of merchantability or fitness for a particular purpose or implied warranty arising out of a course of dealing, custom, or usage of trade whatsoever with respect to these instructions. CUNO shall not under any circumstances be liable to the recipient of these instructions for any direct, indirect, special, incidental, or consequential loss or damages (including, but not limited to, loss of profits, revenue, business, opportunity, or goodwill) resulting from or in any way related to these instructions or the recipient's non-adherence to these instructions, regardless of the legal or equitable theory under which such loss or damages are sought, including breach of warranty or contract, negligence or strict liability.

WARNING: Do not use with water that is microbiologically unsafe or of unknown quality without adequate disinfection before or after the system. Systems certified for cyst reduction may be used on disinfected water that may contain filterable cysts. EPA Establishment Number 070595-CT-001.

CUNO Incorporated recommends regularly scheduled maintenance and replacement of the filter cartridge(s) in order for the product to perform as advertised/sold. **Change the filter cartridge at least every 6 months.** CUNO shall not be liable for system failures due to improper installation, operation or maintenance.



Visit www.nsf.org for the claims associated with products that are NSF listed.



CUNO Incorporated

400 Research Parkway
Meriden, CT 06450, USA
Toll Free: 1.888.218.CUNO
Worldwide: 203.237.5541
Fax: 203.238.8701
www.cunofoodservice.com